



THERMA
PRO

Pre-Finished THERMALLY MODIFIED CLADDING

Nickel Gap T&G Profile

APPLICATIONS

Interior & exterior.
Exterior siding & soffit.
Ceilings & accent walls.

- Size: 1" x 6"
- Texture: Smooth
- Finish:
CUTEK® Extreme
Color-Clear All Sides



WHY THERMAPRO WOOD CLADDING

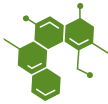

Stable & Solid

Expansion and contraction reduced up to 60%. Resists warping, cupping.



Eco-Friendly

Non-toxic, chemical free process brings out the natural beauty of wood. Fully sustainable building material.



Decay Resistant

Less water absorption means a higher resistance to rot, mold and decay.



Pre-Finished

Pre-Oiled all sides with Cutek Extreme Clear. UV additives available to retain initial wood color.

CLADDING UNITS

10 ft. Unit = 960 sqft | 1920 LF

14 ft. Unit = 1344 sqft | 2688 LF

16 ft. Unit = 960 sqft | 1920 LF



sales@spartanforest.com



(336) 574-0111

Technical Data

PRE-FINISHED THERMALLY MODIFIED CLADDING



Actual Size:

11/16" Thick | 5 3/8" Wide

Lengths:

8' - 16'

Species:

S. Yellow Pine

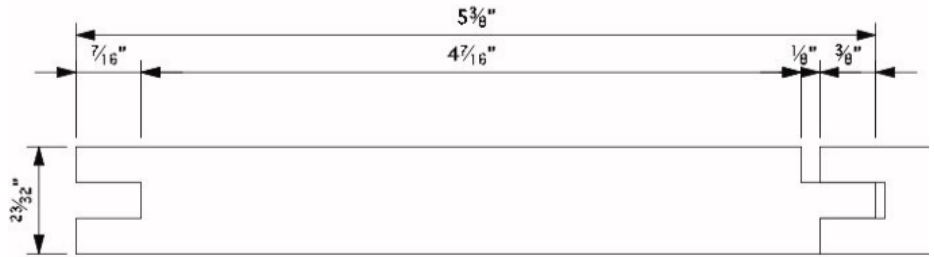

Finishing:

CUTEK® Extreme CD50

- Clear - Standard
- Slows silvering process

Customizations:

- End Match Profile
- 6 Custom Colortones

Manufacturer:

Spartan Forest Products

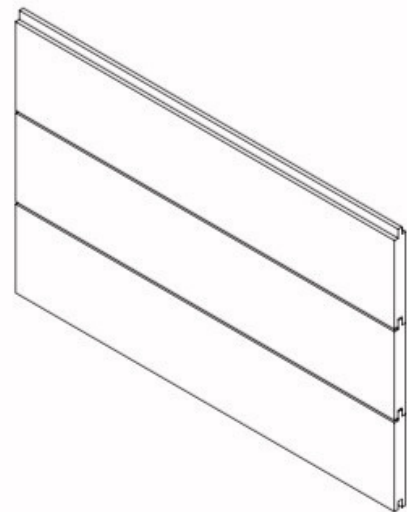

PRE-FINISHING

CUTEK® Extreme Wood Preservative is a high-performance oil based wood stabilizer that penetrates deep into the wood to minimize warping, cupping and splitting. Clear Cutek slows the silvering process. Custom UV protectant Colortones help retain wood coloring. Maintenance coats every 5 years will restore and/or maintain wood coloring.

Clear



Custom Colortones



Honeycomb



White Wash

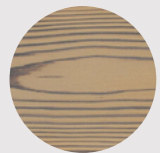

Smokey Gray

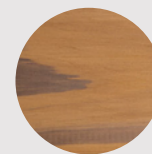

Rustic Gold



Bark

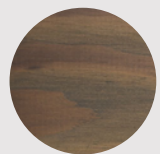

Black Ash

Shown on Southern Yellow Pine



(336) 574-0111



sales@spartanforest.com



www.spartanforest.com